

Trailer specifications

Dimensions and weights

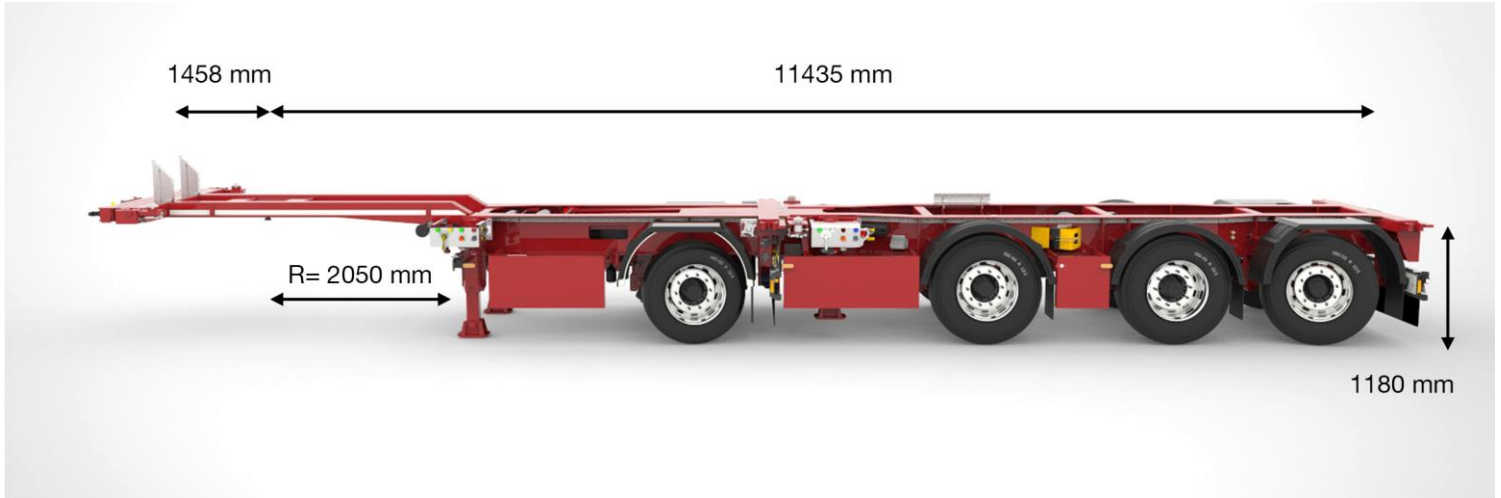

Weights (in tonnes)	Technical	By law
Maximum fifth wheel load	16	NL: 50T total
Maximum bogie load	36	
Gross load capacity	52	DE: 40T total
Tare weight, app.	8.7	
Net load capacity, app.	43.3	UK: 44T total

Your benefits

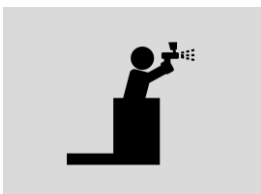

**Ultimate
rustproofing**

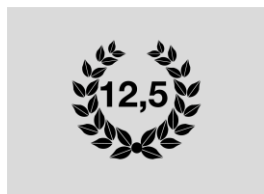

**12.5 years
experience CONnect**



**Easy to load and
unload**

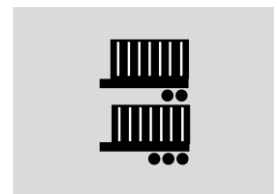

**undertake combined
journeys**

Neck

- The (single beam) neck is suitable for 16T fifth wheel pressure.
- Fixed front beam with Schneider twistlock for fastening through pin or standard container twistlock. Suitable for a gooseneck container and a standard container
- Fifthwheel height 1154 mm with tyre size 385/65 R22,5
- Rear swing clearance 1945 mm
- 2" Kingpin
- On the head of the chassis an extra set of heavy support legs will be supplied to support the chassis during loading or unloading when disconnected from the front the chassis. Always use in combination with regular support
- Landing gear with two speed vertical lift with flat 'T' feet. Static capacity of 50.000 kgs
- 2 galvanised detachable guide stakes are fitted to the front of the trailer for positioning the containers

Floor

- With a central main beam of high tensile steel
- The 5-axle container chassis is a combination of 2 separate fully operational chassis. The 3-axle chassis is connected to the 2 axle chassis by a sliding fifth wheel plate.
Both chassis can transport 1x 20ft container.
Combined they can carry 2x20ft, 1x40ft and 45ft (custom setting), in both the standard as in the highcube version

Axle bogie

- SAF 9 T axles
- First axle is self tracking and liftable
- First two axles are fixed. Third axle is self tracking. The first axle can be lifted
- A plastic tool box fitted on the right side, forming part of the side guards. Dimensions 1.000 x 500 x 500 mm (lxwxh)
- A raise and lower valve is connected to the air suspension for ease of loading or unloading
- Two air line Wabco brake system, EC-approved design with an automatic load sensing device. Spring type chambers fitted to two axles for the hand brake. Incl. EBS
- Tyre brand to choice of Broshuis (Continental, Goodyear or comparable). 385/55 R22,5 und 385/65 R22,5
- Steel rims, light grey
- Half round thermoplastic mudwings fitted to each axle

Lights

- Lights are complete in LED
- 2 pairs of 3-chambers rear lights and LED side-marker-lights. Conform EU-specifications

- 1 pair of reversing lights
- One fog light

Accessories

- EBS connector
- Connectors at the front: Dual 7 pin SAE plugs
- Air couplings palm type
- At the rear axle bogie 1 pair of foldable sections are fitted to support the container when loaded at the neck
- Mudguard under the light bar
- The chassis is equipped with white reflective tape on sides and red reflective tape on the back
- 1 pair of plastic wheel chock

Paintwork

- Finished in one colour. (non-metallic)
- After chassis assembly, the support brackets for valves, air tanks and pipe and wiring runs are fitted. The completed chassis is then shot blasted and immediately painted according to the Broshuis 2K paint system. The final fitting of all the components is carried out after the chassis has been through the preservation process